

# BEARING SOLUTIONS FOR THE AGRICULTURAL INDUSTRY



Utilizing  
**AGXTREME**  
Technology

# AGXTREME™



*Trusted Difference at Every Turn™*



**AGXTREME™**

Today's agricultural industry demand is higher than ever for products that will keep the farmers equipment in the field, operating continuously. Farmers are operating equipment longer, faster and harder and will continue to push the boundaries to increase production. In order to support the top OEM manufacturers of farm equipment, PEER has developed the AGXTREME™ product portfolio.



The AGXTREME™ portfolio consists of the TILLXTREME™, SEEDXTREME™ and TURFXTREME™ product offerings.

Proven through years of research, development and rigorous testing in both lab and field, the advanced sealing technology ensures optimal performance for the customer.

TILLXTREME™ offers a one of a kind, exclusive high-performance solution designed to eliminate the need for relubrication, saving precious hours needed for field work. PEER's patented seal design provides significantly improved contamination exclusion than the conventional triple lip seal design. Products include trunnion units for gang disc, HUB units for independent disc, and both stamped steel and ductile iron units for rolling basket applications.

PEER's TILLXTREME™ engineered assemblies are more reliable, maintenance-free, and simplify installation. As an environmentally friendly solution, there is no grease purge to contaminate the soil.

SEEDXTREME™ offers improved bearing solutions to support manufacturers of seeding equipment. Using our patented seal design and optimized internal bearing construction, PEER offers a range of bearings specifically designed for gauge wheels, disc openers and closing wheels, including integrated flange and shaft HUB design.

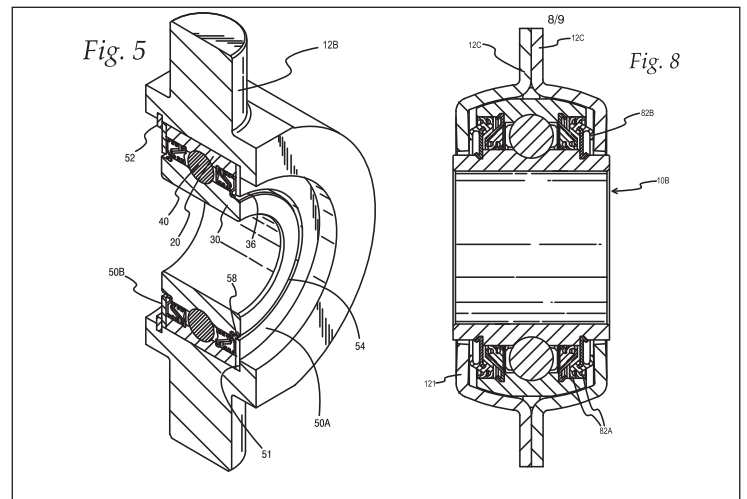

Patent-granted: EP2452090 | US9157475

Whether you have to produce equipment that runs faster or carries higher loads to cover the growing requirements for higher field productivity PEER SEEDXTREME™ bearings have been designed to outperform the competition. These drop in replacements eliminate the need for redesign and increase your speed to market.

TURFXTREME™ offers the Lawn and Garden industry the highest performance bearing seal to provide contamination exclusion and substantially increases the life of lawn and garden equipment, requiring less frequent customer maintenance and greatly reduced cost of machine ownership.



**AGXTREME™ Product Validation**

**Lab Testing / Mud Slurry Testing**

PEER's Research and Development Center utilizes mud slurry testing to thoroughly study new seal concepts before extensive field tests are conducted to validate application performance. The test is performed to determine the effectiveness of the bearing sealing device to provide significantly improved contamination exclusion under aggressive environmental conditions. Seal designs are tested against competitive parts in side-by-side mud slurry.

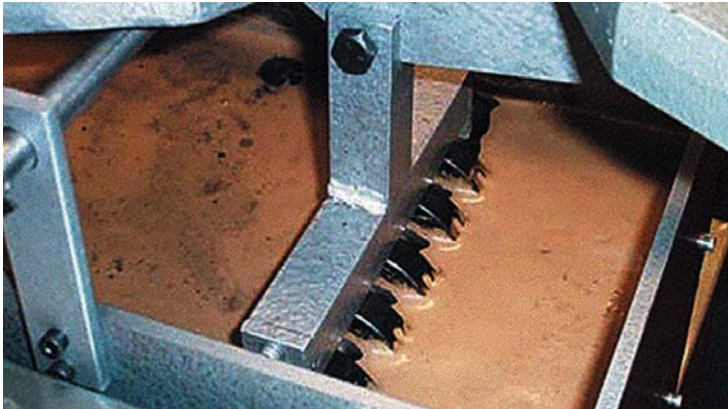

PEER TILLXTREME™  
AFTER 250 HOURS

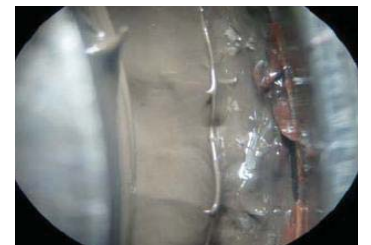

PEER TILLXTREME™  
AFTER 600 HOURS

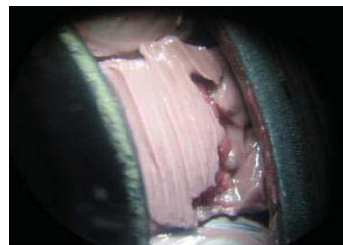

COMPETITOR  
AFTER 250 HOURS



COMPETITOR  
AFTER 600 HOURS



*Trusted Difference at Every Turn™*



#### **About PEER.**

Since 1941, PEER Bearing has grown into an industry leader offering a wide range of highly engineered, precision bearing products. With a strong focus on the agriculture industry, PEER manufactures, develops, and engineers bearing solutions to global market leaders. The PEER product range includes the most comprehensive offering for all agricultural implements, combines and tractors. Our bearings will meet mounting requirements on your equipment to provide an easy drop-in replacement.

From mild to harsh conditions, PEER manufactures high-performance bearings that maximize productivity, increase uptime and eliminate daily maintenance operating costs. Supplying award winning, precision tailored solutions for agricultural equipment starts with an in-depth knowledge and evaluation by industry-specific application engineers. Bearing requirements are translated into engineered solutions, manufactured at our ISO/TS 16949 certified facilities and validated through lab and field testing. With facilities in North America, Europe, Latin America and Asia, we provide solutions for farmers, grounds maintenance and landscapers globally that you can rely on at every turn.

#### **Here is what our customers are saying about their experience with PEER AGXT-REME Bearings:**

*"After one season in Russia, the TILLXTREME™ in the tillage discs performs MORE THAN TWO TIMES better than the previous GREASE relube solution."*

**Luca Rigon, Engineering Manager**  
Tillage Equipment, Maschio Gaspardo

*"The TILLXTREME™ passed 2011 and 2012 tillage seasons in the rolling basket application without any failure and perform way better than the previous solution."*

**Cyril Thirouin, Engineering Director**  
Grégoire-Besson, Rabe Agri

*"The maintenance-free bearings offered by PEER Bearing offer significantly improved bearing life over the traditional bearings being used."*

**Ben Covell, Product Development Manager**  
Great Plains





*Year After Year, PEER Bearing Offers  
Award-Winning Manufacturing, Quality and Delivery*

*Award-Winning Manufacturing, Quality and Delivery*



Case Supplier Quality Assurance Award



Dana Partners in Excellence Award



John Deere Crop Award



John Deere 10 Year Hall of Fame Award



John Deere North American Supplier of the Year Award



Kinze Supplier Performance Award



*Trusted Difference at Every Turn™*

## *PEER® Bearing offers*

- *A comprehensive and wide range of bearings, radial ball bearings and tapered roller bearings*
- *Advanced technological solutions for all kinds of applications*
- *ISO/TS 16949 certified production facilities*
- *A scalable research and development center*
- *World-wide and international customer and application support*

### **Brazil**

PEER Bearing Comércio de Rolamentos Ltda.  
Av. Marginal do Ribeirão dos Cristais, 200  
Bloco 1100, Jordanésia – Cajamar-SP  
Brazil  
CEP 07775-240  
Phone: +55 11 4448-8200  
lam.info@peerbearing.com

### **China**

Shanghai PEER Bearing Co., Ltd.  
9/F, Tower B, Central Towers  
#567 Langao Road  
Putuo District, Shanghai,  
P.R. China  
Phone.: +86 21 61484816  
sales@peerchina.com

### **Germany**

PEER Bearing GmbH  
Gruitener Str. 23  
40699 Erkrath  
Germany  
Phone: +49 2104 1 42 63 -0  
europe.info@peerbearing.com

### **Italy**

PEER Bearing S.R.L.  
Via Paolo Nanni Costa, 12/3 A  
40133 Bologna  
Italy  
Phone: +39 051 6120405  
europe.info@peerbearing.com

### **United States**

PEER Bearing  
2200 Norman Drive  
Waukegan, IL 60085  
USA  
Phone: +1 847 578 1000  
info@peerbearing.com

® PEER is a registered trademark of the PEER Group of Companies.

™ Trusted Difference at Every Turn is a trademark of the PEER Group of Companies.

™ AGXTREME, TILLXTREME and TURFXTREME are trademarks of PEER Bearing Company.



Trusted Difference at Every Turn™



### SEEDXTREME™

#### Bearing solution for seeding equipment

##### Benefits and functional features

- Increased productivity and bearing life in field
  - ⇒ Exclusive patented seal design with improved contamination exclusion extends bearing life and can be paired with upgraded, wear-resistant disc blades
  - ⇒ Pre-assembled, engineered HUBs reduce assembly and labor cost while eliminating bearing damage due to incorrect component design and assembly
- Increased speed to market
  - ⇒ SEEDXTREME™ covers all critical row unit bearings from coulter disk to the closing wheel

#### PEER Mud Slurry Test Results

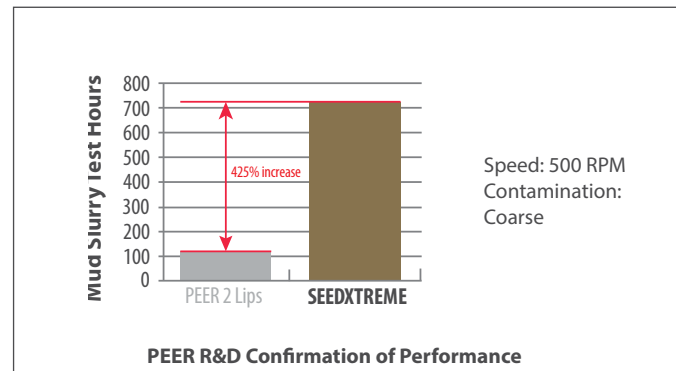



Trusted Difference at Every Turn™

**SEEDXTREME™**

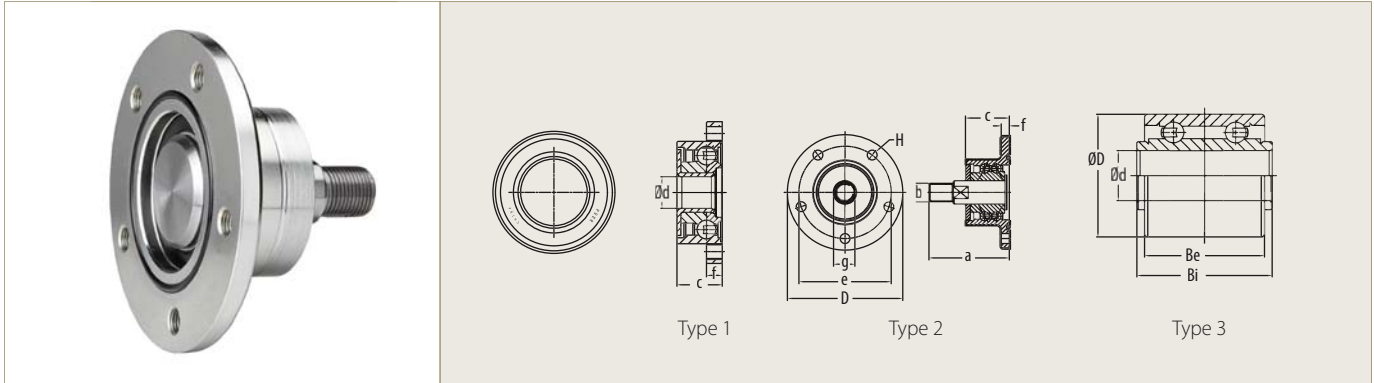

**HUB unit for the disc opener**

PEER Part Number	Type	b	e		p		c		a		d		H	f	
			[inch]	[mm]	[inch]	[mm]	[inch]	[mm]	[inch]	[mm]	[inch]	[mm]		[inch]	[mm]
HUB-16MM-X	1	/	/	/	2.8346	72	2.8346	23	0.9055	23	0.9055	72	M8 x 1.0. 6x	0.315	8

**HUB unit for row mounted disc coultter**

PEER Part Number	Type	b	e		p		c		a		d		H	f		g	
			[inch]	[mm]	[inch]	[mm]	[inch]	[mm]	[inch]	[mm]	[inch]	[mm]		[inch]	[mm]	[inch]	[mm]
HUB-20MM-X	2	M16x2	2.24409	57	3.937	100	1.4961	38	2.874	73	3.937	100	8.5 H12. 5x	0.2756	7	0.72835	18.5

**Bearing for gauge or closing wheel**

PEER Part Number	Type	d		D		Bi		Be	
		[mm]	[inch]	[mm]	[inch]	[mm]	[inch]	[mm]	[inch]
5203-KMF-R-A120	3	16.256	0.64	40	1.5748	44.12	1.737	39.12	1.5402





Trusted Difference at Every Turn™



**TILLXTREME™**

**Flanged Unit Assembly for Rolling Basket  
Stamped Steel Rolling Basket Bearings  
More Productivity and Environmentally Friendly**

It takes time and money to maintain traditional tillage bearings. TILLXTREME™ solutions are maintenance free which keeps the machine working in field instead of sitting idle for service allowing for up to 15% more productivity for the farmers. This can result in up to 25 more tilled acres (10 ha) per day and a significant saving in material and labor cost.

\* the chart reflects estimated savings when Trunnion and FD units are mounted. Based on internal calculation and estimated total savings. Actual results may vary.

**Benefits and functional features**

- Bolt-on-performance
  - ⇒ Directly interchangeable industry standard units
  - ⇒ Static misalignment capability accommodates imprecise mounting surfaces
- Increased productivity and bearing life in field
  - ⇒ Dynamic misalignment capability eliminates internal bearing damage and housing wear
  - ⇒ Shock load protection due to thick riveted steel housings
  - ⇒ Exclusive patented sealing system eliminates the need for relubrication
- Increased speed to market
  - ⇒ PEER offers the industry's largest range of round and square bore sizes

**Bearing Maintenance Cost \***

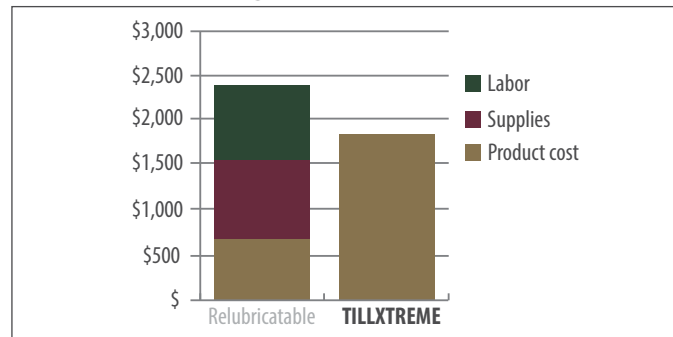

**Average Acres/Hectare Per Day\***

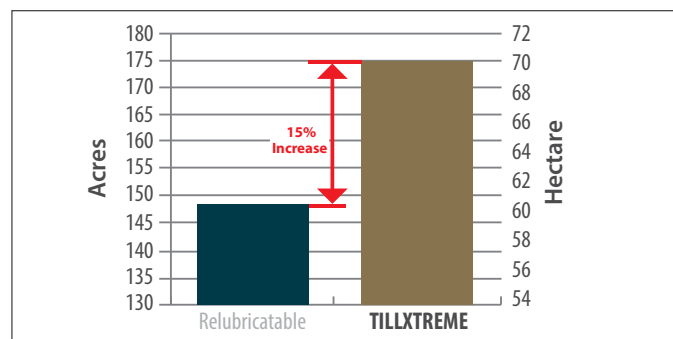

**FD Unit Mud Slurry Test Results**

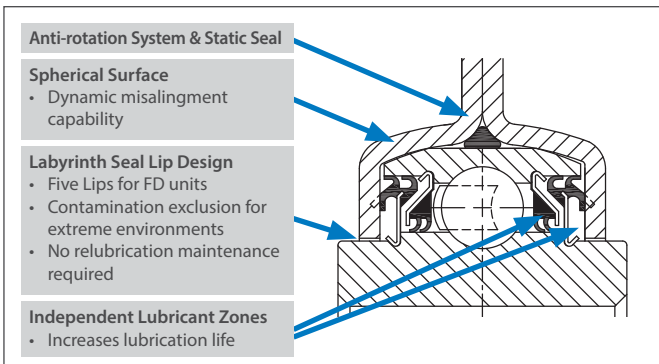
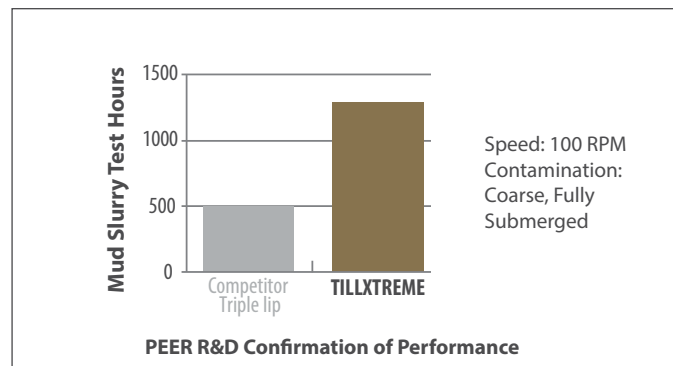



Trusted Difference at Every Turn™

**TILLXTREME™**

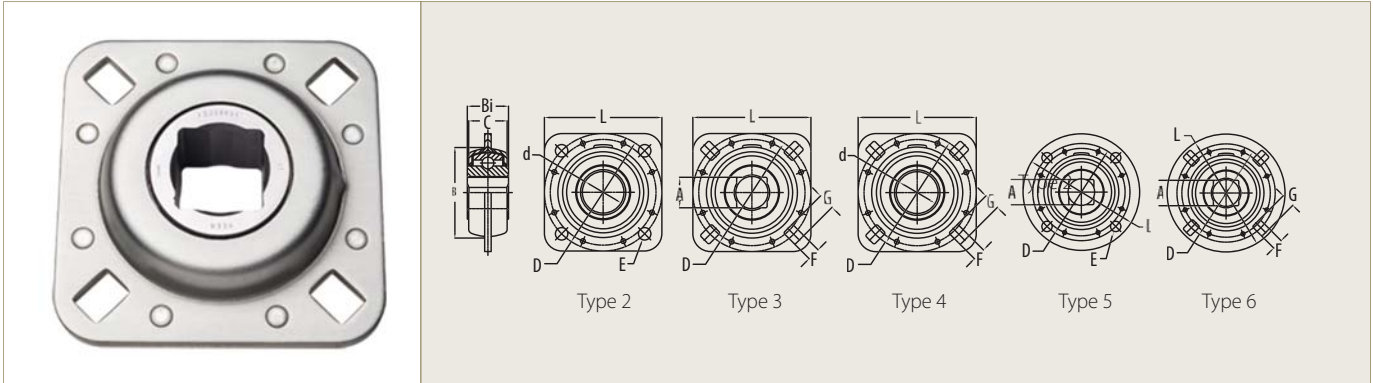

**Stamped Steel Flange Disc Assemblies - Round Bore**

PEER Part Number	TYPE	d ROUND SHAFT		Bi		L		D BOLT CIRCLE		E		F		G		B MIN. FRAME OPENING		C	
		IN	MM	IN	MM	IN	MM	IN	MM	IN	MM	IN	MM	IN	MM	IN	MM	IN	MM
FD209K58-1-3/4RD-A326	2	1.7700	44.958	1.6845	42.786	5.0000	127.000	5.0000	127.000	0.5310	13.487	-	-	-	-	3.8650	98.170	1.6300	41.400
FD209K50-1-3/4RD	2	1.7700	49.958	1.7470	44.374	5.0000	127.000	5.0000	127.000	0.5310	13.487	-	-	-	-	3.8650	98.170	1.6300	41.400
FD209K52-1-1/2RD	4	1.5350	38.989	1.6845	42.786	5.0000	127.000	5.0000	127.000	-	-	0.5310	13.487	0.6870	17.450	3.8650	98.170	1.6300	41.400
FD209K54-1-1/4RD	2	1.2700	32.258	1.6845	42.786	5.0000	127.000	5.0000	127.000	0.5310	13.487	-	-	-	-	3.8650	98.170	1.6300	41.400
FD211K65-1-15/16RDC-A326	2	1.9380	49.253	2.1250	53.975	139.7000	5.5000	5.5000	139.700	0.5310	13.487	-	-	-	-	4.4910	114.070	1.8110	46.000
FD211K52-1-3/4RD-A365	2	1.7800	45.212	2.1875	55.562	5.5000	139.700	5.5000	139.700	0.5310	13.490	-	-	-	-	4.4910	114.070	1.8110	46.000
FD211K61-2-3/16RD	2	2.1880	55.575	2.1845	55.486	5.5000	139.700	5.5000	139.700	0.5310	13.487	-	-	-	-	4.4910	114.070	1.8110	46.000
FD212K51-60RD	2	2.4016	60.000	2.2047	56.000	6.8110	173.000	5.6300	143.000	06.400	16.250	-	-	-	-	5.0000	127.000	1.9680	50.000

**Stamped Steel Flange Disc Assemblies - Square Bore**

PEER Part Number	TYPE	A SQUARE SHAFT		Bi		L		D BOLT CIRCLE		E		F		G		B MIN. FRAME OPENING		C	
		IN	MM	IN	MM	IN	MM	IN	MM	IN	MM	IN	MM	IN	MM	IN	MM	IN	MM
FD209K51-1-1/4SQ	3	1.6845	42.786	5.0000	127.000	5.0000	127.000	5.0000	127.000	-	-	0.5310	13.487	0.6870	17.450	3.8650	98.170	1.6300	41.400
FD209K57-1-1/8SQ-A366	3	1.6845	42.786	5.0000	127.000	5.0000	127.000	5.0000	127.000	-	-	0.5310	13.487	0.6870	17.450	3.8650	98.170	1.6300	41.400
FD211K53-1-1/2SQ	3	2.0000	50.800	5.5000	139.700	5.5000	139.700	5.5000	139.700	-	-	0.5310	13.490	0.6870	17.450	4.4910	114.070	1.8110	46.000
RFD209K50-1-1/8SQ	6	1.6845	42.786	6.0000	152.400	5.0000	127.000	5.0000	127.000	0.5310	13.500	-	-	-	-	3.8650	98.170	1.6300	41.400
RFD209K51-30MMSQ-SP2	5	1.6845	42.786	6.0000	152.400	5.0000	127.000	5.0000	127.000	-	-	0.5310	13.500	0.5310	13.500	3.8650	98.170	1.6300	41.400
RFD211K51-40MMSQ-A371	5	2.0078	52.000	7.5590	192.000	5.5000	139.700	5.5000	139.700	-	-	0.5900	15.000	0.5900	15.000	4.4910	114.070	1.8110	46.000



Trusted Difference at Every Turn™



**TILLXTREME™**  
**Flanged Unit Assembly for Rolling Basket**  
**Ductile Iron Rolling Basket Bearing**

It takes time and money to maintain traditional tillage bearings. TILLXTREME™ solutions are maintenance free which keeps the machine working in field instead of sitting idle for service.

**Benefits and functional features**

- Bolt-on-performance
  - ⇒ Directly interchangeable industry standard units
  - ⇒ Compensates misalignment from imprecise mounting or frame surfaces
- Increased productivity and bearing life in field
  - ⇒ Shock load protection due to high grade ductile iron housing
  - ⇒ Exclusive sealing system eliminates the need for relubrication

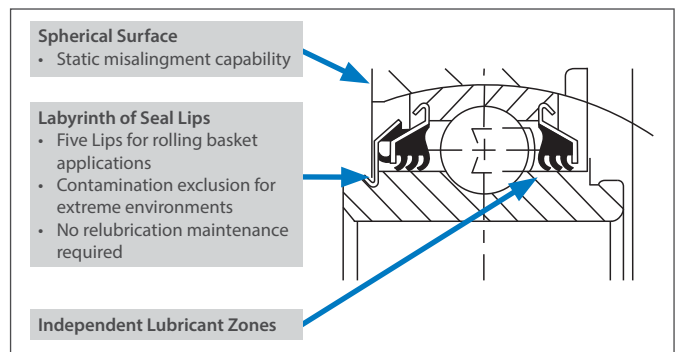

**PEER Mud Slurry Test Results**

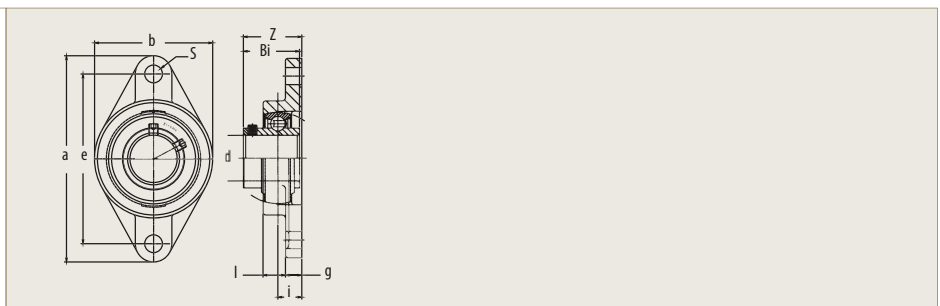
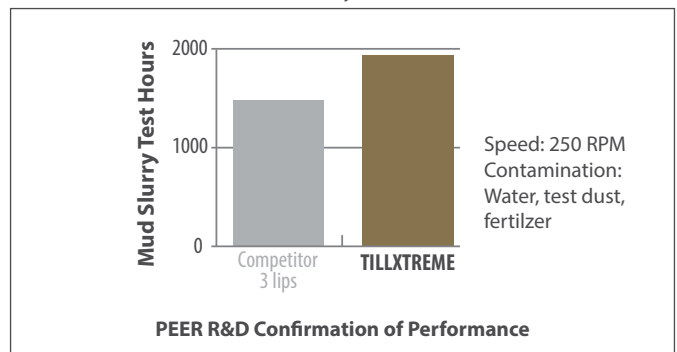

UCFT Units PEER Part Number	d		a		e		i		g		l		s		z		Bi		b	
	[inch]	[mm]	[inch]	[mm]	[inch]	[mm]	[inch]	[mm]	[inch]	[mm]	[inch]	[mm]	[inch]	[mm]	[inch]	[mm]	[inch]	[mm]	[inch]	[mm]
XD-UCFT206-30MM-XB-AP-TLSL-U236	1.181	30	5.811	147.6	4.594	116.7	0.709	18	0.5	12.7	1.142	29	0.531	13.5	1.646	41.8	1.563	39.7	3.157	80.2

TILLXTREME™

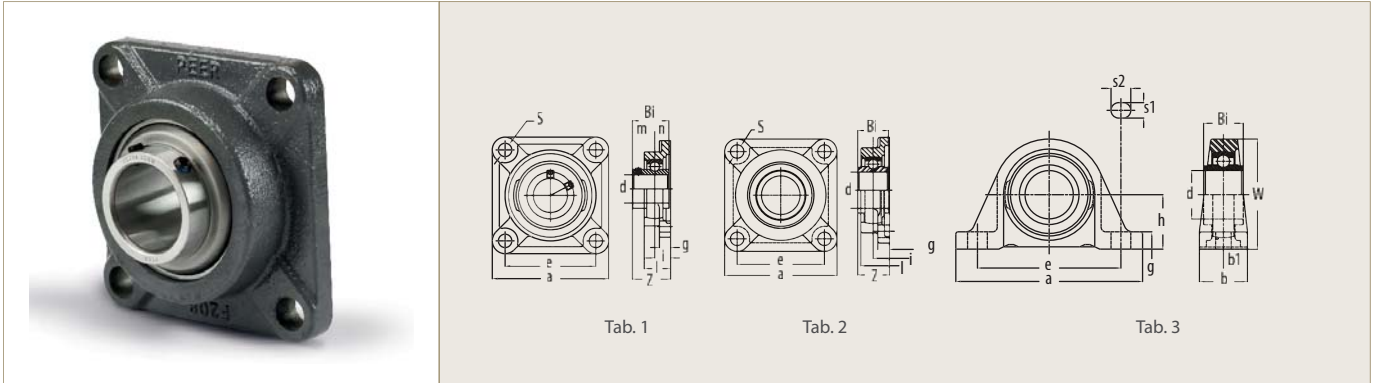

Tab. 1

UCF Units PEER Part Number	d Round Shaft		a		e		i		g		l		s		Z		Bi		n		m	
	[inch]	[mm]	[inch]	[mm]	[inch]	[mm]	[inch]	[mm]	[inch]	[mm]	[inch]	[mm]	[inch]	[mm]	[inch]	[mm]	[inch]	[mm]	[inch]	[mm]	in	[mm]
XD-UCF210-50MM-XB-AP-TLSL-U117	1.969	50	5.626	142.9	4.374	111.1	0.874	22.2	0.626	15.9	1.563	39.7	0.65	16.5	2.157	54.8	2.0315	51.6	0.748	19	1.2835	32.6
UCF208-40MM-MFTRL	1.575	40	5.126	130.2	4	101.6	0.835	21.2	0.594	15.1	1.406	35.7	0.65	16.5	2.024	51.4	1.937	49.2	0.748	19	1.189	30.2
UCF308-40MM-AP-MF	1.575	40	5.906	150	4.409	112	0.906	23	0.669	17	1.575	40	0.748	19	2.205	56	2.047	52	0.748	19	1.299	33
UCFS210-50MM-AP-BSLS-U265	1.969	50	5.626	142.9	4.374	111.1	1.142	29	0.626	15.9	1.811	46	0.669	17	2.425	61.6	2.0315	51.6	0.748	19	1.2835	32.6
XD-UCF209-45MM-AP-TLSL-U26	1.772	45	4.252	108	5.843	148.4	0.866	22	0.594	15.1	1.378	35	0.669	17	2.055	52.2	1.937	49.2	0.748	19	1.189	30.2
XD-UCF212-60MM-XB-AP-TLSL-U26	2.362	60	6.874	174.6	5.626	142.9	1.158	29.4	0.72	18.3	1.874	47.6	0.709	18	2.72	69.1	1.937	49.2	0.748	19	1.189	30.2

Tab. 2

W212-F Units PEER Part Number	d Round Shaft		a		e		i		g		l		s		Z		Bi	
	[inch]	[mm]	[inch]	[mm]	[inch]	[mm]	[inch]	[mm]	[inch]	[mm]	[inch]	[mm]	[inch]	[mm]	[inch]	[mm]	[inch]	[mm]
W212-60MM-FDT-MF	2.362	60	6.874	174.6	5.626	142.9	1.158	29.4	0.72	18.3	1.874	47.6	0.709	18	2.1575	54.8	2	50.8
W210-50MM-MF-R-DF-A362	1.969	50	5.626	142.9	4.374	111.1	1.093	27.75	0.591	15	1.622	41.2	0.669	17	1.841	46.75	1.496	38
W208-40MM-MF-R-DFT-A374	1.575	40	6.874	174.6	5.657	143.7	1.22	31	0.563	14.3	1.772	45	0.65	16.5	2.008	51	1.575	40

Tab. 3

W212-P Units PEER Part Number	d Round Shaft		h		a		e		b		s1		s2		g		W		Bi	
	[inch]	[mm]	[inch]	[mm]	[inch]	[mm]	[inch]	[mm]	[inch]	[mm]	[inch]	[mm]	[inch]	[mm]	[inch]	[mm]	[inch]	[mm]	[inch]	[mm]
W212-60MM-P-MF	2.3622	60.000	2.750	69.850	9.4374	239.710	7.250	184.150	2.4252	61.600	0.7811	19.840	1.000	25.400	0.8752	22.230	5.5626	141.290	2.000	50.800



Trusted Difference at Every Turn™



## TILLXTREME™

### HUB Bearings

#### Bearings for Independent Disc Applications

It takes time and money to maintain traditional tillage bearings. TILLXTREME™ solutions are maintenance free which keeps the machine working in field instead of sitting idle for service.

#### Benefits and functional features

- Bolt-on-performance
  - ⇒ The integrated flange design replaces an external housing
  - ⇒ Reduces labor cost and eliminates damage due to incorrect assembly
- Increased productivity and operation life in field
  - ⇒ Shock load protection from forged steel integrated flange
  - ⇒ Eliminates internal bearing damage
  - ⇒ Exclusive patented sealing system eliminates the need for relubrication
- Increased speed to market
  - ⇒ PEER offers the industry's largest range of high performance tillage HUBs

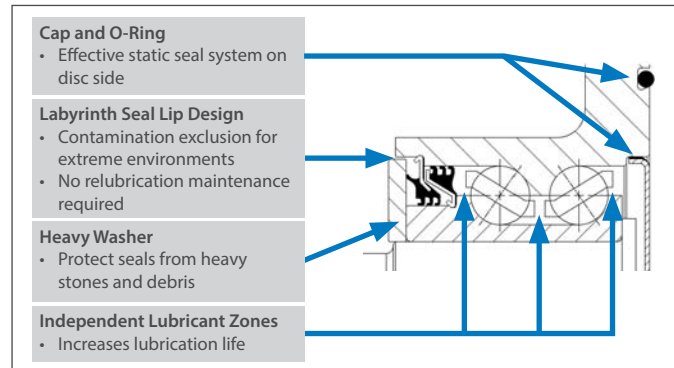

TILLXTREME™

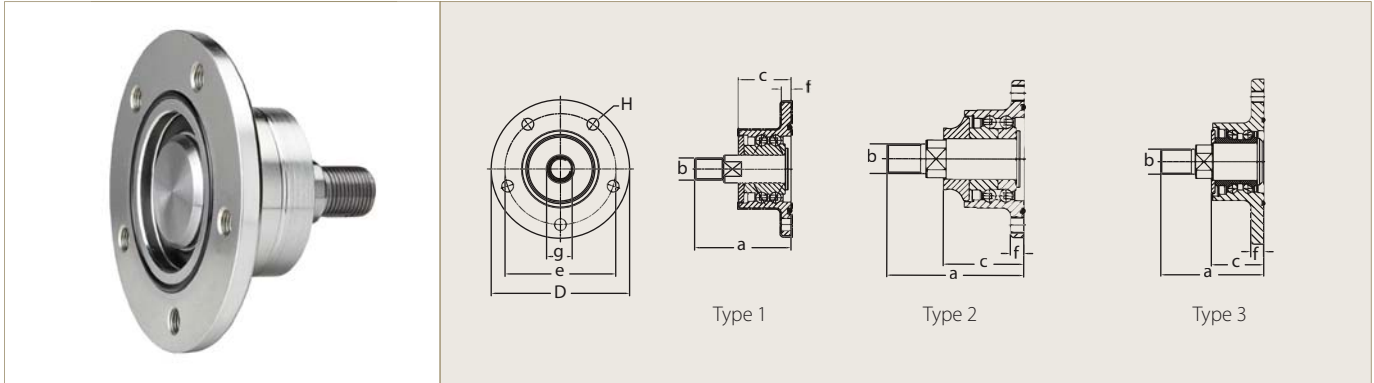

PEER Part Number	Type	b	e		p		c		a		d		H Bolt	f		g	
			[inch]	[mm]	[inch]	[mm]	[inch]	[mm]	[inch]	[mm]	[inch]	[mm]		[inch]	[mm]	[inch]	[mm]
HUB-20MM-X	1	M16 x 2.00	2.2441	57	3.1496	80	1.4961	38	2.8740	73	3.9370	100	5 x M8 x 1.00	0.2756	7	0.7283	18.5
HUB-30MM	2	M22 x 1.50	3.0610	77.75	3.8583	98	1.7717	45	3.4646	88	4.6063	117	4 x M12 x 1.25			1.0039	25.5
HUB-30MM-X-ASSY-A221	3	M22 x 1.5	2.9134	74	3.8583	98	3.8583	60	2.3622	104	4.0945	117	4 x M12 x 1.25	0.3937	10	1.0039	25.5
HUB-30MM-X-ASSY-A249	3	M22 x 1.5	2.9134	74	3.8583	98	3.8583	60	2.3622	102	4.0157	117	6x M12 x 1.25	0.3937	10	1.0039	25.5
HUB-30MM-X-ASSY-A452	3	M22 x 1.25	2.9134	74	3.8583	98	3.8583	60	2.3622	102	4.0157	117	5 x M12 x 1.25	0.3937	10	1.0039	25.5
HUB-35MM	2	M24 x 2.00	3.1496	82	4.4094	112	2.0275	51.5	3.8780	98.5	5.5118	140	5 x M12 x 1.50	0.4134	10.5	1.1024	28
HUB-35MM-X-ASSY-A243	2	M24 x 2	3.1496	81	3.1890	150	5.9055	61	2.4016	116	4.5669	178	6 x M12 x 1.25	0.4134	10.5	1.1024	28
HUB-40MM-X-ASSY-A436	2	M27 x 2.00	3.4547	87.75	5.5118	140	2.1654	55	4.3701	111	7.0079	178	5 x M12 x 1.25	0.5512	14	1.3189	33.5



Trusted Difference at Every Turn™



**TILLXTREME™**

**Trunnion Unit Bearing Units for Gang Disc Applications  
More Productivity and Environmentally Friendly**

It takes time and money to maintain traditional tillage bearings. TILLXTREME™ solutions are maintenance free which keeps the machine working in field instead of sitting idle for service allowing for up to 15% more productivity for the farmers. This can result in up to 25 more tilled acres (10 ha) per day and a significant saving in material and labor cost.

\* the chart reflects estimated savings when Trunnion and FD units are mounted. Based on internal calculation and estimated total savings. Actual results may vary.

**Benefits and functional features**

- Bolt-on-performance
  - ⇒ Directly interchangeable industry standard units
  - ⇒ Static misalignment capability accommodates imprecise mounting surfaces
- Increased productivity and bearing life in field
  - ⇒ Dynamic misalignment capability eliminates internal bearing damage
  - ⇒ Shock load protection due to high grade ductile iron housing
  - ⇒ Exclusive patented sealing system eliminates the need for relubrication
- Increased speed to market
  - ⇒ PEER offers the industry's largest range of round and square bore sizes

**Bearing Maintenance Cost \***

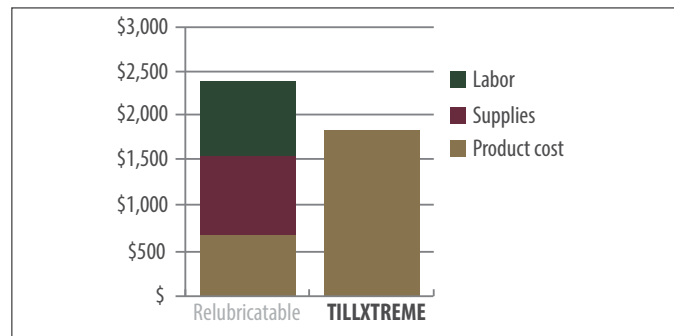

**Average Acres/Hectare Per Day\***

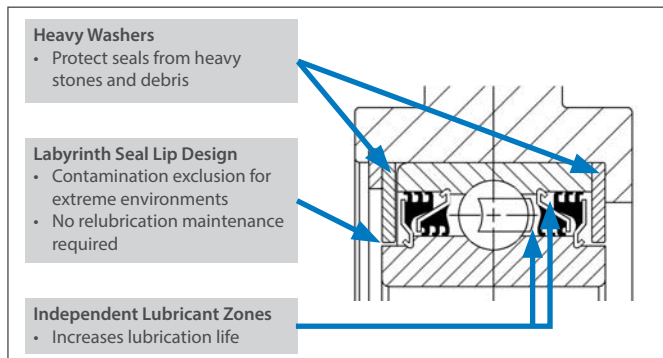
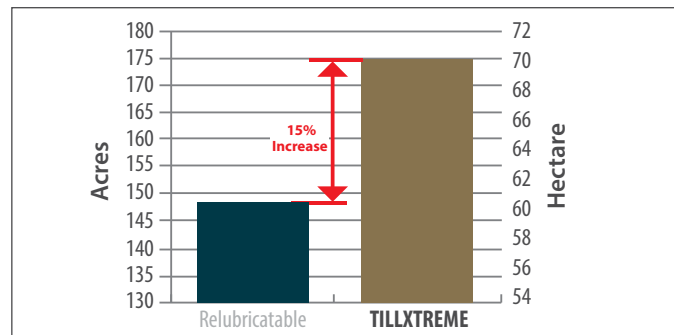

**Trunnion Unit Mud Slurry Test Results**

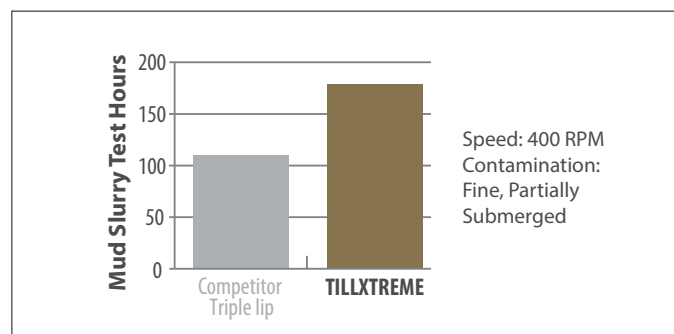

**Independent Test Lab Confirmation of Performance**

**TILLXTREME™**

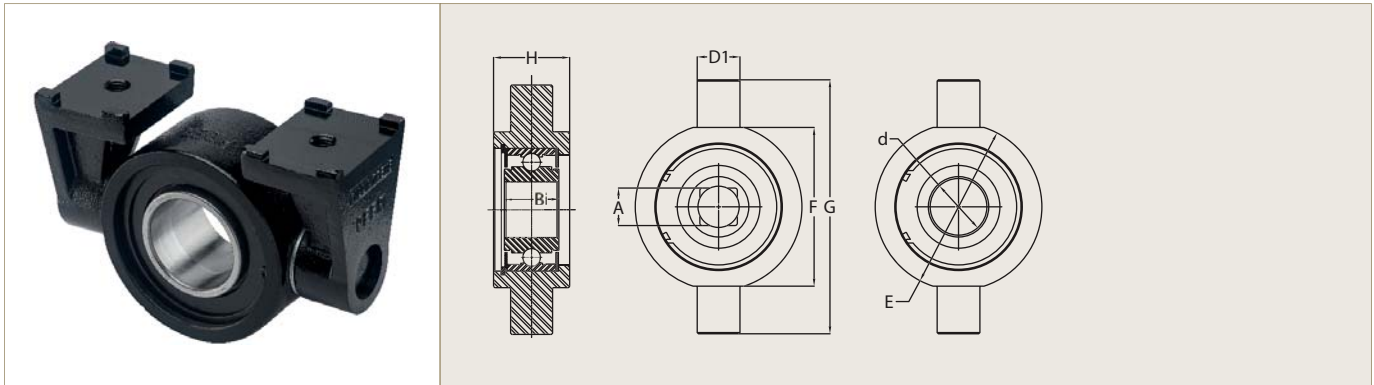

**Trunnion Units for Gang Disc Applications**

PEER Part Number	d		A Square Shaft		Bi		D1		E		F		G		H	
	in	mm	in	mm	in	mm	in	mm	in	mm	in	mm	in	mm	in	mm
W211K56-TTU	1.7850	45.339	/	/	1.7500	44.450	1.375	34.925	5.250	133.350	5.000	127.000	65.090	203.200	2.441	62.000
W211K58-TTU	1.9692	50.018	/	/	1.9685	50.000	1.375	34.925	5.250	133.350	5.000	127.000	65.090	203.200	2.441	62.000
W211K59-TTU	/	/	1.500	38.100	1.7500	44.450	1.375	34.925	5.250	133.350	5.000	127.000	65.090	203.200	2.323	59.000
W214K51-TTU	2.6881	68.278	/	/	2.6875	68.262	1.500	38.100	6.000	152.400	6.000	152.400	76.200	228.600	2.992	76.000
W214K52-TTU	2.2800	57.912	/	/	2.6875	68.262	1.500	38.100	6.000	152.400	6.000	152.400	76.200	228.600	2.992	76.000

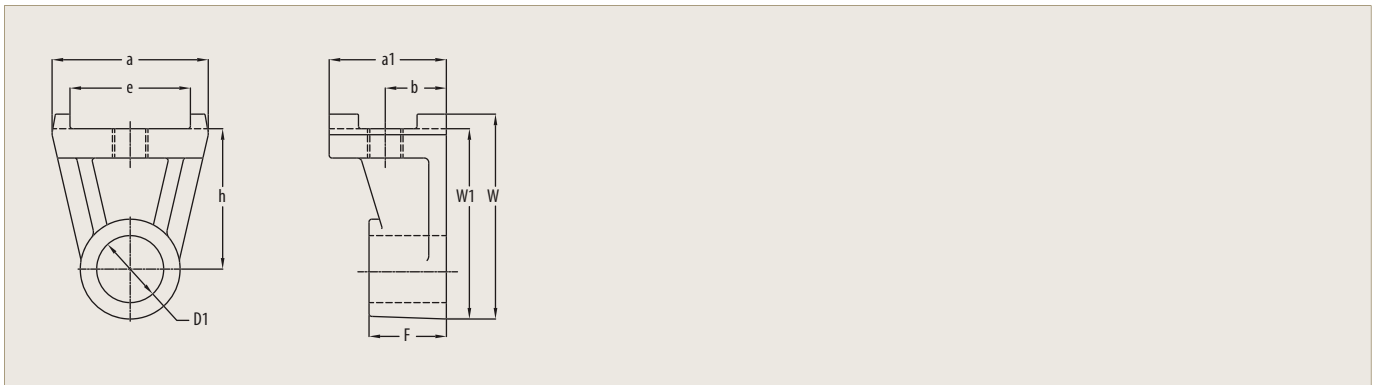

**Hangers for Gang Disc Applications**

PEER Part Number	e		a		h		D1		a1		b		F		W		W1	
	in	mm	in	mm	in	mm	in	mm	in	mm	in	mm	in	mm	in	mm	in	mm
HANGER-211	2.5625	65.088	3.188	80.980	3.000	76.200	1.4375	36.512	2.500	63.500	1.375	34.930	1.625	41.280	4.403	111.840	4.0913	103.920
HANGER-214	3.0000	76.200	3.780	96.000	3.543	90.000	1.5312	38.892	2.835	72.000	1.457	37.000	1.654	42.000	5.000	127.000	4.7240	120.000





Trusted Difference at Every Turn™



**TURFXTREME™**  
**Bearing Solutions for Lawn & Garden Equipment**

**Benefits and functional features**

- Long bearing life results in
  - ⇒ Less customer maintenance and reduced cost of machine ownership
  - ⇒ Reduced OEM warranty exposure and cost
  - ⇒ Strengthened OEM product and brand integrity

**PEER Mud Slurry Test Results**

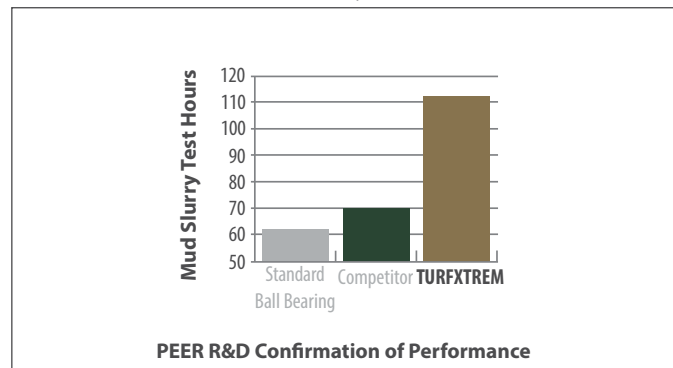

Feature	Benefit
Contact sealed for life	• Contamination prevention
High quality through hardened bearing steel	• Improves fatigue life
Precision ground and superfinished raceways	• Reduces vibration and extends life
Premium polyurea thickened grease	• Excellent high and low temperature capability • Excess grease life
Increased grease fill	• Improves corrosion protection during machine idle periods
Premium nitrile seal material composition	• Longer seal life due to improved high temperature and wear resistance
Optimized seal design	• Maintains seal integrity when exposed to external force due to wrapping debris and pressure washing
Precision ground seal contact surface	• Smooth surface finish results in longer seal lip life • Improves ring concentricity which results in increased seal effectiveness
Increased seal lip contact	• Improves contamination exclusion in extreme environments
Heavy gauge steel shroud	• Protects seal from large solid contamination (stones, pebbles, dirt)



Typical Standard Ball Bearing Seal (32 hours)



Competitor Seal for L&G Applications (32 hours)



PEER 2RSTFP Seal (32 hours)



Trusted Difference at Every Turn™

**TURFXTREME™**

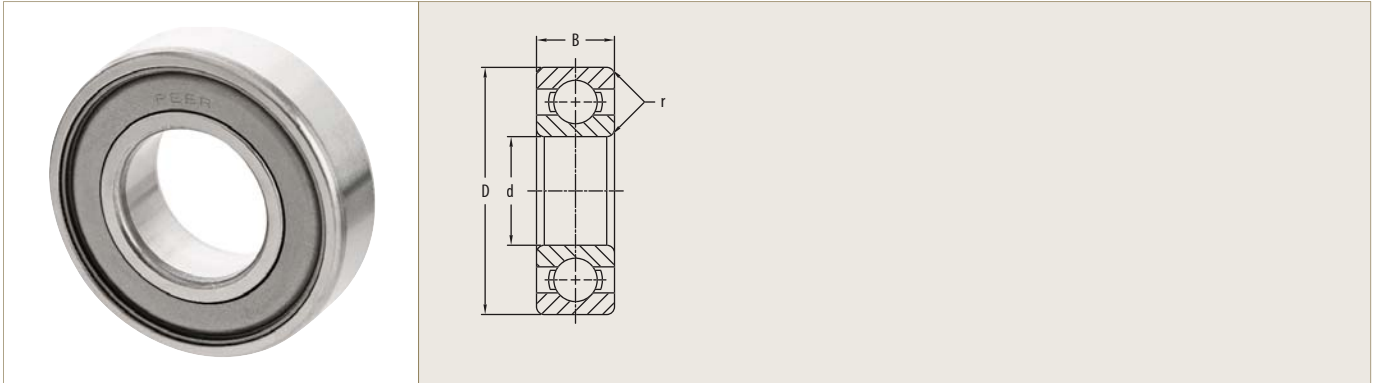

**Deep groove ball bearing common size**

PEER Part Number	Seal Design Designation Contamination Exclusion Capability Xtreme	d		D		B		r	
		mm	in	mm	in	mm	in	mm	in
6203	-2RSTFP	17.000	0.6693	40.000	1.5748	12.000	0.4724	0.60	0.024
6204	-2RSTFP	20.000	0.7874	47.000	1.8504	14.000	0.5512	1.00	0.039
Z9504	-2RSTFP	19.016	0.7504	45.220	1.7805	15.490	0.6100	1.00	0.039
6205	-2RSTFP	25.000	0.9843	52.000	2.0472	15.000	0.5906	1.00	0.039
6206	-2RSTFP	30.000	1.1811	62.000	2.4409	16.000	0.6299	1.00	0.039
6207	-2RSTFP	35.000	1.3780	72.000	2.8346	17.000	0.6693	1.10	0.043
6305	-2RSTFP	25.000	0.9843	62.000	2.4409	17.000	0.6693	1.10	0.043

**Lawn and garden bearing size**

